

## HAV IgM Rapid Test Cassette (Serum/Plasma)

REF: 1192 001 30 test

### INTENDED USE

The Spectrum HAV IgM Rapid Test is a lateral flow chromatographic immunoassay for the qualitative detection of IgM antibodies to Hepatitis A virus (HAV) in human serum or plasma. It is intended to be used as a screening test and as an aid in the diagnosis of infection with HAV. Any reactive specimen with the Spectrum HAV IgM Rapid Test must be confirmed with alternative testing method(s) and clinical findings.

### SUMMARY

HAV is a positive-sense RNA virus, a unique member of picornaviridae<sup>1</sup>. Its transmission depends primarily on serial transmission from person to person by the fecal-oral route. Although hepatitis A is not ordinarily a sexually transmitted disease, the infection rate is high among male homosexuals as result of oral-anal contact. The presence of specific anti-HAV IgM in blood samples suggests acute or recent HAV infection. The IgM antibody rapidly increases in titer over a period of 4-6 weeks post infection and then declines to non-detectable levels within 3 to 6 months in most patients<sup>7</sup>. The Spectrum HAV IgM Rapid Test is to be used to detect IgM anti-HAV in less than 15 minutes by untrained or minimally skilled personnel, without cumbersome laboratory equipment.

### TEST PRINCIPLE

The test is based on a proprietary technology that combines the principles of immune-chromatography and fluid dynamics. The test has the recombinant mouse anti-human IgM immobilized on the membrane within the test zone. During the test the serum or plasma add on the sample port(S) reacts with mouse anti-human IgM on the membrane first. The buffer run upward from buffer well (B), HAV antigen reacts to particle coated with mouse anti-HAV migrates through the test zone, the HAV antigens are captured by the HAV antibody in the first step. It indicates positive result when the test zone form of a colored line, no colored line in the test zone indicates a negative result. To serve as a procedural control, a colored line will always appear in the control line region indicating that proper volume of specimen has been added and membrane wicking has occurred.

### REAGENTS AND MATERIALS PROVIDED

The test cassette contains anti-HAV antibody particles, HAV nature antigen on the antigen pad and mouse anti-human IgM on the membrane.

1. Test Cassettes
2. Buffer
3. Sample dilution tubes
4. Droppers
5. Package inserts.

### MATERIALS REQUIRED BUT NOT PROVIDED









- Specimen collection container
- Timer
- Centrifuge

### WARNINGS AND PRECAUTIONS

For in Vitro Diagnostic Use

1. This package insert must be read completely before performing the test. Failure to follow the insert gives inaccurate test results.
2. Do not open the sealed pouch unless ready to conduct the assay.
3. Do not use expired devices.
4. Bring all reagents to room temperature (15°C-30°C) before use.
5. Do not use the components in any other type of test kit as a substitute for the components in this kit.
6. Do not use hemolyzed blood specimens for testing.

#### SYMBOLS IN PRODUCT LABELLING

	Authorised Representative		Temperature Limitation
	For in-vitro diagnostic use		Use by/Expiration Date
	Batch Code/Lot number		CAUTION. Consult instructions for use
	Catalogue Number		Manufactured by
	Consult instructions for use		

7. Wear protective clothing and disposable gloves while handling the kit reagents and clinical specimens. Wash hands thoroughly after performing the test.
8. Users of this test should follow the US CDC Universal Precautions for prevention of transmission of HIV, HBV and other blood-borne pathogens.
9. Do not smoke, drink or eat in areas where specimens or kit reagents are being handled.
10. Dispose of all specimens and materials used to perform the test as bio-hazardous waste.
11. Handle the negative and positive controls in the same manner as patient specimens.
12. The testing results should be read within 15 minutes after a specimen is applied to the sample well or sample pad of the device. Reading the results after 15 minutes may give erroneous results.
13. Do not perform the test in a room with strong air flow, i.e. electric fan or strong air-conditioning

### REAGENT PREPARATION AND STORAGE INSTRUCTION

All reagents are ready to use as supplied. Store unused test devices unopened at 2°C-30°C. If stored at 2°C-8°C, ensure that the test device is brought to room temperature before opening. The test device is stable through the expiration date printed on the sealed pouch. Do not freeze the kit or expose the kit over 30°C.

### SPECIMEN COLLECTION AND PREPARATION

Consider any materials of human origin as infectious and handle them using standard bio-safety procedures.

#### Plasma

1. Collect blood specimen into a lavender, blue or green top collection tube (containing EDTA, citrate or heparin, respectively in Vacutainer®) by veinpuncture.
2. Separate the plasma by centrifugation.
3. Carefully withdraw the plasma into new pre-labeled tube.

#### Serum

1. Collect blood specimen into a red top collection tube (containing no anticoagulants in Vacutainer®) by veinpuncture.
2. Allow the blood to clot.
3. Separate the serum by centrifugation.
4. Carefully withdraw the serum into a new pre-labeled tube.

Test specimens as soon as possible after collecting. Store specimens at 2°C-8°C if not tested immediately.

Store specimens at 2°C-8°C for up to 5 days. The specimens should be frozen at -20°C for longer storage.

### TEST PROCEDURE

Allow the test cassette, specimen, buffer and/or controls to reach room temperature (15-30°C) prior to testing.

#### 1. Sample Dilution

Use micropipette to add 50µL specimen into the sample dilution tube. Screw the lid tightly and shake it for 10 seconds to ensure the solution could be well mixed. Use the diluted sample as specimen for testing. See instruction below.

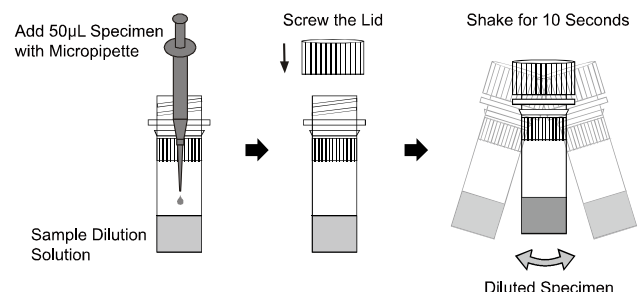

## 2. Testing Procedures

- Remove the test cassette from sealed pouch and use it within one hour. Best results will be obtained if the assay is performed immediately after opening foil pouch.
- Hold the dropper vertically, draw the diluted specimen from sample dilution bottle upto the fill line marked on the dropper as shown in illustration below (approx.5µL), transfer the diluted specimen to the **sample area (S)** which has been marked on the test cassette. Or use micropipette to add 5µL diluted specimen into the **sample area (S)** which has been marked.
- Add 2 drops of buffer (approx. 80µL) into the **buffer well (B)** marked on the test cassette, start the timer. See illustration below.
- Wait for the colored line(s) to appear. Read the result at 20 minutes, do not interpret the result after 30 minutes.

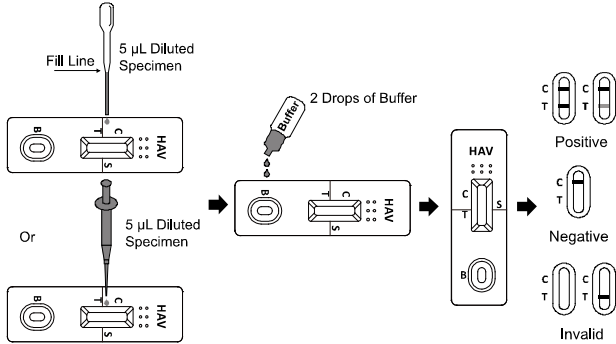

## INTERPRETATION OF RESULTS

(Please refer to the illustration above)

**POSITIVE:**\* Two distinct colored lines appear. One line should be in the control line region (C) and another line should be in the test line region (T).

**\*NOTE:** The intensity of the color in the test line region (T) may vary depending on the concentration of HAV IgM present in the specimen. Therefore, any shade of color in the test line region (T) should be considered positive.

**NEGATIVE:** One colored line appears in the control line region (C). No apparent colored line appears in the test line region (T).

**INVALID:** Control line fails to appear. Insufficient specimen volume or incorrect procedural techniques are the most likely reasons for control line failure. Review the procedure and repeat the test with a new test. If the problem persists, discontinue using the test kit immediately and contact your local distributor.

## QUALITY CONTROL

- Internal Control:** This test contains a built-in control feature, the C line. The C line develops after adding the specimen and the sample diluent. If the C line does not develop, review the whole procedure and repeat the test with a new device.
- External Control:** Good Laboratory Practice recommends using external controls, positive and negative, to assure the proper performance of the assay, particularly under the following circumstances:
  - New operator uses the kit, prior to performing the testing of specimens.
  - A new lot of test kits is used.
  - A new shipment of kits is used.
  - The temperature used during storage of the kits fall outside of 2-30°C.
  - The temperature of the test area falls outside of 15-30°C.
  - To verify a higher than expected frequency of positive or negative results.
- To investigate the cause of repeated invalid results

## LIMITATIONS OF TEST

- The Assay Procedure and the Interpretation of Assay Result sections must be followed closely when testing for the presence of anti-HAV IgM in serum or plasma from individual subjects. Failure to follow the procedure may give inaccurate results
- The Spectrum HAV IgM Rapid Test is limited to the qualitative detection of anti-HAV IgM in human serum or plasma. The intensity of

the test line does not have linear correlation with the antibody titre in the specimen.

- A negative result for an individual subject indicates absence of detectable anti-HAV IgM. However, a negative test result does not preclude the possibility of exposure to or infection with HAV.
- A negative result can occur if the quantity of the anti-HAV IgM present in the specimen is below the detection limits of the assay or the antibodies that are detected are not present during the stage of disease in which a sample is collected.
- Some specimens containing unusually high titers of heterophile antibodies or rheumatoid factor may affect expected results.
- The results obtained with this test should only be interpreted in conjunction with other diagnostic procedures and clinical findings.

## Expected Values

The HAV IgM Rapid Test Cassette (Serum/Plasma) has been compared with a leading commercial HAV EIA test. The correlation between these two systems is over 99%.

## PERFORMANCE CHARACTERISTICS

Method	ELISA		Total Results	
	Result	Positive		Negative
HAV Rapid Test (WB/Serum/Plasma)	Positive	180	2	182
	Negative	0	550	550
		180	552	732

Relative Sensitivity: >99.9% (95%CI:\*98.3%-100%)

Relative Specificity: 99.6% (95%CI:\*98.7%-99.9%)

Overall accuracy: 99.7% (95%CI:\*99.0%-99.9%)

## REFERENCES

- Minor P. Picornaviridae. In: Francki RIB, Fauquet CM, Knudson DL, et al., eds. Classification and nomenclature of viruses (Arch Virol Supp 2). Wien: Springer-Verlag, 1991: 320-326.
- Keeffe EB. Clinical approach to viral hepatitis in homosexual men. Med Clin North Am. 1986;70(3):567-86.
- Ballesteros J, Dal-Re R, Gonzalez A, del Romero J. Are homosexual males a risk group for hepatitis A infection in intermediate endemicity areas? Epidemiol Infect. 1996; 117(1):145-8.
- Bradley DW, Maynard JE, Hindman SH, et al: Serodiagnosis of viral hepatitis A: Detection of acute-phase immunoglobulin M anti-hepatitis A virus by radioimmunoassay. J Clin Microbiol 1977; 5: 521-530.
- Decker RH, Kosakowski SM, Vanderbilt AS, et al: Diagnosis of acute hepatitis A by HAVAB-M : A direct radioimmunoassay for IgM anti-HAV. Am J Clin Pathol 1981;76:140-147.
- Locarnini SA, Ferris AA, Lehman NI, et al: The antibody response following hepatitis A infection. Intervirology 1974; 4:110-118.
- Skinhoj P, Mikkelsen F, Hollinger FB. Hepatitis A in Greenland: Importance of specific antibody testing in epidemiologic surveillance. Am J. Epidemiol 1977; 105: 104-147.

**Egyptian Company for Biotechnology (S.A.E)**  
 Obour city industrial area. block 20008 piece 19 A. Cairo. Egypt.  
 Tel: +202 4489 2248 - Fax: +202 4489 2247  
 www.spectrum-diagnostics.com  
 E-mail:info@spectrum-diagnostics.com

